



**VALVE REGULATED
LEAD ACID BATTERY (V.R.L.A.)**



**ABSORBED GLASS MAT
TECHNOLOGY (A.G.M.)**



**10 YEAR DESIGN FOR UPS AND
STANDBY APPLICATIONS**



Features

- Gas recombination greater than 99%.
- Operates at a low internal pressure.
- Never needs watering, minimal maintenance.
- 99.7% pure lead calcium grids.
- Shock absorbent thick wall construction.
- Cold forged non-porous terminal bushings, eliminate post leakage.
- Thermally welded case to cover bond, eliminates both acid and electrical leaks.
- Over-sized, through the partition inter-cell welds provide low resistance connections, with minimal power loss.
- Each cell has a low pressure safety release venting system, recognized per U.L. 924.
- Measured high vacuum acid fill, reduces electrical variability between cells.
- 100% recyclable materials.

Options

- The TC-12100S battery has a flame retardant polypropylene case and cover compliant with UL 1778; with an oxygen index greater than 28%.
- Terminal covers and custom inter-connecting battery cables.

Specifications

Cells per unit	6
Nominal voltage	12
Terminal type	1/4" Stud
Maximum discharge current	600 amps
Short circuit current	3366 amps
Impedance @ 77°F 25°C	4.10 milliohms
Weight lbs / kgs	71.9 / 32.6
Electrolyte (S.G.)	1.300
Capacity @ 77°F (25°C) to 1.75 V.P.C.	91.0 AH (20 hrs) 82.4 A.H. (8 hrs)
Ideal operating temperature range	+68°F (+20°C) to +77°F (+25°C)
Extended operating temperature range	Discharge: -40°F (-40°C) to +140°F (+60°C) Charge: -40°F (-40°C) to +122°F (+50°C)
Float Voltage	13.5 to 13.8 @ 77°F (25°C)
Maximum charging current	C/4 amperes at 100% discharge Unlimited at partial discharge.
AC ripple from charging source	1.5% peak to peak of float charge voltage
Storage	6 months at 77°F (25°C)

No transport restrictions

- Surface transport. Classified as non-hazardous material as relates to DOT-CFR Title 49 part 171-189.
- Maritime transport. Non hazardous as per IMDG amendment 27.
- Air transport. Complies with IATA / ICAO, special provision A67.

DISCHARGE SPECIFICATIONS

Constant power ratings, Watts per battery @ 77°F (25°C) in minutes										
Final V.P.C.	5	10	15	20	30	40	45	50	60	90
1.60	3371	2501	1930	1579	1170	939	865	791	688	502
1.67	3257	2454	1909	1564	1161	933	860	787	685	501
1.70	3207	2436	1896	1555	1157	930	857	785	684	497
1.75	3041	2293	1827	1525	1146	922	850	778	678	496

Specifications subject to change without notice

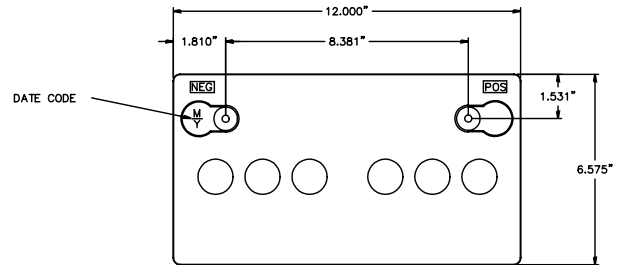
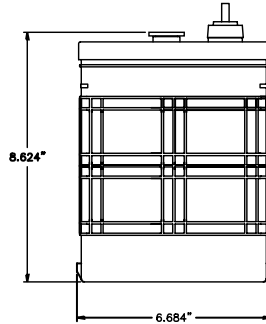
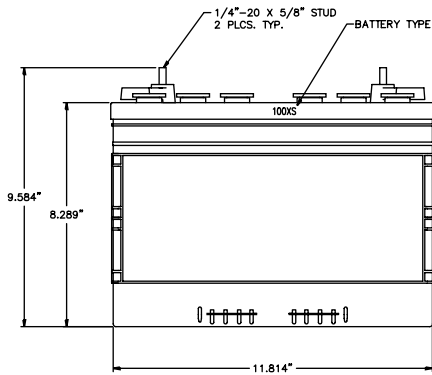

CR3 cabinet model

Power Battery offers an extensive line of pre-wired and fused battery cabinets complete with UL and CUL approval. Standard and custom DC voltages complete with breakers and chargers are available.

Battery Cabinet Systems (pre-wired with PRC/TC-12100S batteries)					
Battery cabinet model	Maximum # of batteries	Dimensions			Weight lbs / kgs
		inches / millimeters			
		W	D	H	
KS5	2	15.0 / 381	25.0 / 635	15.75 / 400	181 / 85.8
KS6	4	16.0 / 406	34.5 / 876	17.75 / 451	367 / 166.8
KS7	8	16.0 / 406	34.5 / 876	37.25 / 946	733 / 333
CR1	12	24.0 / 610	32.5 / 826	43.0 / 1092	1135 / 567.5
CR3	20	40.0 / 1016	32.5 / 826	43.0 / 1092	1784 / 810.9
CR6	30	40.0 / 1016	32.5 / 826	60.0 / 1524	2629 / 1195
CR4	40	40.0 / 1016	32.5 / 826	77.0 / 1956	3474 / 1579.1

Constant current ratings, Amperes @ 77°F (25°C) in hours

Final V.P.C.	1	2	3	4	5	6	8	10	12	24
1.75	57.1	33.2	24.1	19.0	15.6	13.3	10.3	8.40	7.17	3.87
1.80	56.3	32.9	23.9	18.6	15.4	13.1	10.2	8.35	7.11	3.82
1.85	54.1	32.0	23.1	18.0	14.9	12.7	9.80	8.07	6.86	3.69
1.90	49.7	29.9	21.7	17.0	14.0	11.9	9.10	7.46	6.28	3.41

U.S.A.
Power Battery Company, Inc.
 25 McLean Blvd.
 Paterson, N.J. 07514-1507
 Phone: (973) 523-8630
 Fax: (973) 523-3023
 E-mail: sales@powbat.com
 Web page: www.powerbattery.com

CANADA
Power Battery (Iberville) Ltd.
 770 Thomas Ave.
 Iberville, Québec, J2X 5E7
 Phone: (450) 346-3273
 Fax: (450) 346-8003
 E-mail: powerbat@sympatico.ca
 Web page: www.powerbattery.com

UK
Power Batteries Ltd.
 Premier Way, Abbey Park Industrial Estate
 Romsey, Hampshire, SO51 9AQ
 Phone: +44 (0)1794 835900
 Fax: +44 (0)1794 835910
 E-mail: sales@powbat.co.uk
 Web page: www.powbat.co.uk

ITALY
Italian Sales Office
 Via Locatelli 105
 20046 Biassono MI - ITALY
 Phone: +(39) 039 2324571
 Fax: +(39) 039 2499200
 E-mail: calberti@powbat.co.uk
 Web page: www.powbat.co.uk